

Version: 1.0.12 Status: 26.06.2020 Page 1 of 25	specification production parts	<div style="text-align: right;"> <small>AUTOMATION</small> baumann </div> Released by: StrobelJo
--	--	---

Specifications for production parts

(for production and suppliers)

- 1** *Reasons for the specification of production parts* **2**
- 2** *General description*..... **2**
- 3** *Material choice* **3**
- 4** *Tolerances/Dimensions* **3**
- 5** *Requirements for large aluminium panels* **5**
- 6** *Engravings*..... **6**
- 7** *Requirements for sheet metal parts*..... **6**
- 8** *Requirements for test objects/measurement logs* **13**
- 9** *Requirements for welded parts* **14**
- 10** *Requirements for glass panes* **15**
- 11** *tidiness* **16**
- 12** *ESD* **16**
- 13** *Painting/surface coating*..... **16**
- 14** *Quality, packaging and delivery conditions* **18**
- 15** *complaint*..... **18**
- 16** *key to the symbols* **19**
- 17** *document history* **24**

Version: 1.0.12 Status: 26.06.2020 Page 2 of 25	specification production parts	 Released by: StrobelJo
--	---	--

1 Reasons for the specification of production parts

Due to the increasing complexity of components, there are more and more additional fields and abbreviations on drawings that make the entire drawing more complex. In many cases, the same symbols always appear on the drawings with which the suppliers of Baumann GmbH are very familiar. However, there are also certain symbols or drawing comments that are very company-specific and can be ambiguous. In order to make the drawings clear, these additions are deliberately kept as short as possible. In case of ambiguities on the drawings, this "specification sheet" can be consulted in which certain drawing supplements are explained in more detail. This "specification sheet for production parts", which is **always** valid, is intended to provide information on the quality and accuracy of the parts to be produced. Should further queries nevertheless arise, please contact the "Drawing Hotline" at: 09621/67 54 214.

2 General description

Article number

At Baumann GmbH, the production parts have unique article numbers. If you have any questions about the drawing, component or product, please always have the article number ready.

Old article numbers (K-numbers) can be converted as follows:

Current article number:	K-00007645
Replace the characters "K-" with a "1":	100007645
A "-" is used as thousands separator:	100-007-645

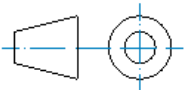
Allgemeintoleranzen: General tolerances: ISO2768-mK		Ausnahme für Allgemeintoleranzen: Längenmaße: über / over 120 exception for general tolerances: linear measures: bis / up to 4000 ±0,3	
 Oskar-von-Miller-Str. 7 fon +49 (0) 9621 6754 0 92224 Amberg Germany fax +49 (0) 9621 6754 922		Scale 1:5 EN AW-ALMg4,5Mn (Fortal5083-G5-S)	
			
		Title Tisch - Platte - -	
		Article number 100-102-081	
1: Zk M4 hinzu Ø10 14.01.14		1 / 1	
2: Durchbruch/Befestigung Sicherh 31.01.13		A1	
Stufe		Project: PRO.FILE-ID: 10242209 B	

Amendment directory



If changes occur to components, these are documented and explained on the drawing in the title block. The changed elements, such as bore distances, number of holes, threads, external dimensions, etc. are marked on the drawing with the symbol in the heading. If "revised" or "completely revised" is indicated, the changes were so extensive that an explanation of the individual changes would have become too confusing. If there is a dot (".") or a dash ("-") in the second column of the change history, there was **no** change despite the change notice and no symbol appears in the drawing. The component was accidentally "modified". A distinction is made between a revision (major change) and a change index. With a new revision (e.g. "B") the change index always starts at "0". Therefore only revision+change index in combination (e.g. "C0" is newer than "B2") are unique!

Version: 1.0.12 Status: 26.06.2020 Page 3 of 25	specification production parts	<div style="text-align: right; background-color: #cccccc; padding: 2px;"> <small>AUTOMATION</small> baumann </div> Released by: StrobelJo
--	---	--

3 **Material choice**

Manufacturing parts for which a material certificate is required must also be manufactured from the material specified in the drawing. If "standard materials" are specified in the drawing, e.g.

- S235
- Al
- stainless steel

If there are no special requirements for the exact material, surface or heat treatment, the supplier can decide for himself the exact specification of the material within the material group.

For all other materials specified in the drawing, the components must be manufactured from the required or higher quality material. In case of doubt, a short consultation should be held (telephone: 09621/67 54 214).

If the surface treatment is indicated in the material field, pre-treated semi-finished products may be used. In this case, the end faces + machined surfaces do not have to be post-treated. This applies to the following materials, for example:

- - S235JR, galvanized
- - EN AW-ALMgSi0.5 - anodized/anodized (anodizing color is always "natural")

The following materials are available for plastic protective screens:

- "PC"
- "PC, antistatic" Colour: colourless: = raw material "EUROPLEX-SDX-F"
- "PC, antistatic" Colour: tinted = raw material "ESLON® PC Sheet 427 smoke brown, antistatic".

The protective screens must be delivered with protective film, preferably 100µm, but at least 70µm.

4 **Tolerances/Dimensions**

The tolerances and dimensions indicated on the drawing must be observed. If machined dimensions are not tolerated, the general tolerance ISO 2768-mK indicated in the labelling field shall apply to these dimensions/surfaces. Except for length measurements over 120mm to 4000mm, here the tolerance of ±0.3mm specified in the labelling field applies.

The principle of independence according to DIN ISO 8015 always applies, even if there are no corresponding notes on the drawing. Surfaces with fitting or tolerance dimensions must be flat and parallel to each other according to the tolerance size.

Marked unmachined external dimensions remain in the raw state. Here the tolerance of the respective standard of the starting material must be observed.

E.g. FI 60 * 10 * 200 DIN174 1.0037

Thickness h11 (h12); straightness (length) "directed towards the eye"

If there is no explicit surface specification on the drawing at the end face of the component or if the general specification for aluminium components is "Ra6.3" or for steel components "Ra12.5", a saw cut at the ends of the semi-finished products is sufficient.

specification production parts

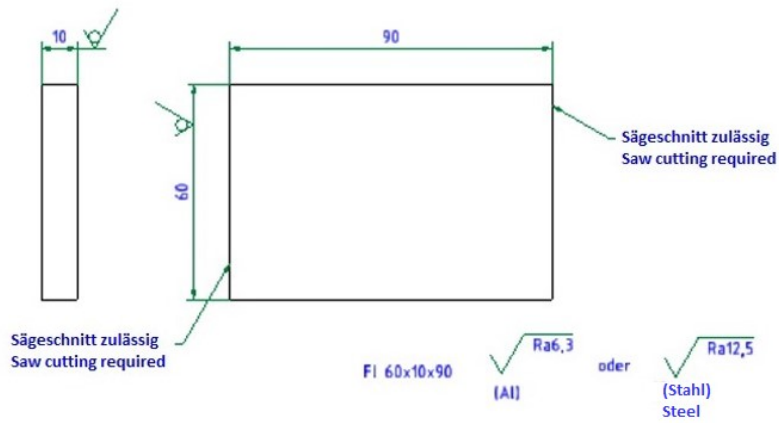

5 Requirements for large aluminium panels

Unless otherwise indicated on the drawings, the following tolerances apply **after** finishing to all Fortal5083-G5-S plates or better:

G5-S (fine milled)	
surface roughness	Ra 3.2
parallelism	$< \frac{0,1}{3000}$ ($\hat{=}$ 0,1mm je 3 meter length)
evenness	$< 0,2$ mm je meter length
component thickness tolerance	$\pm 0,1$
Length and width tolerance	+ 0,0 - 0,5

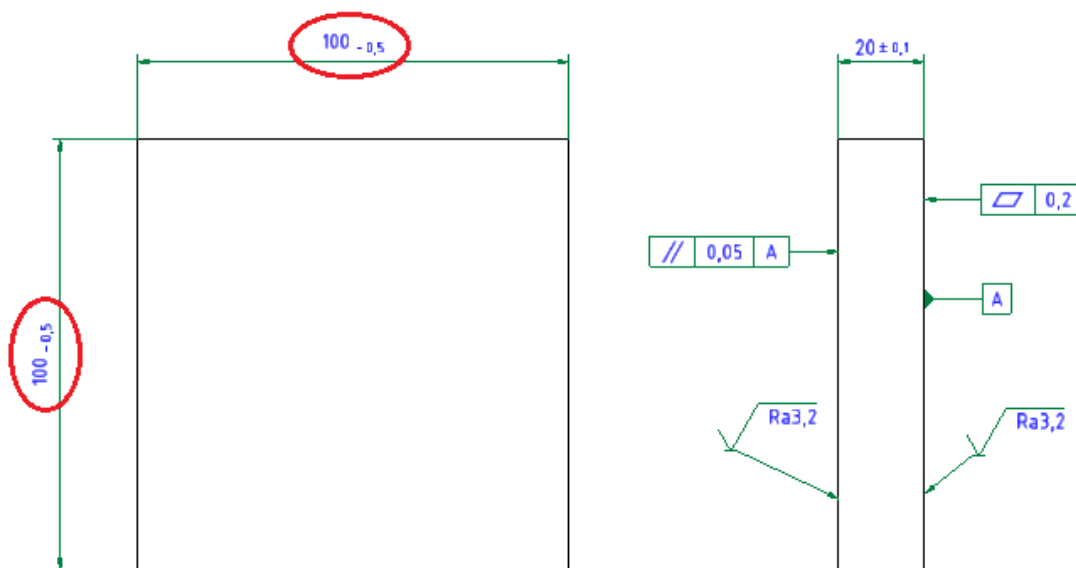

Version: 1.0.12 Status: 26.06.2020 Page 6 of 25	specification production parts	<small>AUTOMATION</small> baumann Released by: StrobelJo
--	---	--

6 Engravings

If possible, all engravings or labels will be made with the font "Arial" and, if not otherwise specified, with a font height of 3 mm. A smaller font height can of course be used for small components or small marking areas.

When engraving/labelling, care must be taken to ensure that these do not penetrate into holes (etc.) or protrude beyond the component itself. In addition, the position of the title block indicated on the drawing must be observed. Unless otherwise stated, engravings may be milled or produced by laser. The prerequisite, however, is that the engravings are clearly legible (even after a possible surface coating)!



7 Requirements for sheet metal parts

- Dimensions of sheet metal parts**

For sheet metal parts (as well as for surface elements such as PC or Makrolon sheets or surface seals), only the dimensions typically required in the manufacturing process are dimensioned. The following applies to all undimensioned elements: The dimensions can be taken from the .step model!

The following rules apply to dimensioning:

dimensioned	undimensioned
Bending dimensions	Dimensions that have nothing to do with bending
Bending angle (if $\neq 90^\circ$)	Bending radius
Sheet thickness	Bending angle 90°
Threads (only dimension)	Hole position and dimension
Countersinks (only dimension)	radius/chamfers
Dimensions of the unfolded view (as reference)	
annotations (general, edge transitions, text engraving, changes, etc.)	
Tolerances that are more accurate than general tolerances	

for all undimensioned elements the general tolerances according to DIN EN ISO 9013 Tolerance class 1 apply, for sheet thickness >1 to $\leq 3,15$ thus applies:

nominal dimension	$>0 <3$	$\geq 3 < 35$	$\geq 35 < 315$	$\geq 315 < 4000$
limiting dimension	$\pm 0,1$	$\pm 0,2$	$\pm 0,3$	$\pm 0,4$

For all linear dimensions produced by forming (bending) the tolerances according to DIN 6930 part 2 m apply:

Nominal dimension	1 to 6	over 6 to 10	over 10 to 25	over 25 to 63	over 63 to 160	over 160 to 400	over 400 to 1000	over 1000 to 2500
limiting dimension for sheet thickness over 1 to 3	±0,2	±0,3	±0,4	±0,6	±0,8	±1,2	±1,6	±2,4
limiting dimension for sheet thickness over 3 to 6	±0,4	±0,5	±0,6	±0,8	±1,0	±1,2	±2	±3

The tolerances according to DIN EN ISO 13920 B apply to all length dimensions produced by welding:

nominal dimension	0 to 30	over 30 to 120	over 120 to 400	over 400 to 1000	over 1000 to 2000	over 2000 to 4000
limiting dimension	±1,0	±2,0	±2,0	±3,0	±4,0	±6,0

- Deburring of components**

With sheet metal parts, it must be ensured that all cut edges are cleanly deburred. Sharp-edged "noses" are not permitted and must also be removed.

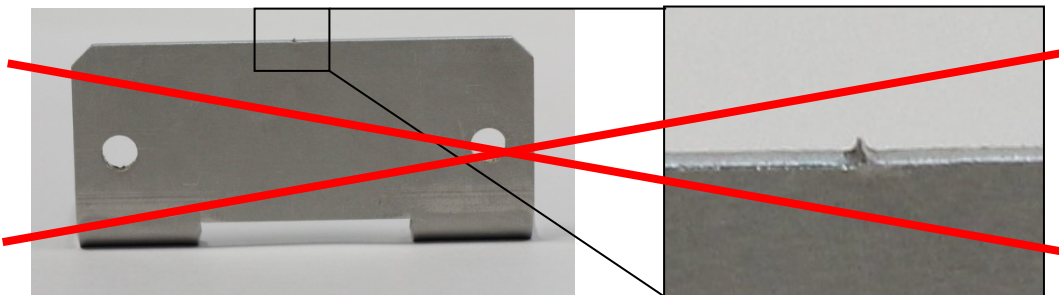

- Impressions during bending**

If there is no comment on the drawing, impressions resulting from bending are permissible.

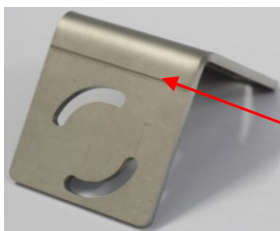

Impression caused by the bending.

Version: 1.0.12 Status: 26.06.2020 Page 8 of 25	specification production parts	<small>AUTOMATION</small> baumann Released by: StrobelJo
--	---	--

- **perforation**

The outer dimensions of perforated components are specified and relevant. The width of the perforation groove can be selected at will and should be between 1mm and 2mm if possible. The number of webs and positions must be selected in such a way that the part to be broken out is sufficiently firmly connected to the rest on the one hand and can be broken out with only a few cuts on the other.

- **Design with information "Spot welded" or "Tightly welded".**

If the respective passage is indicated on a drawing, this is to be carried out as follows:

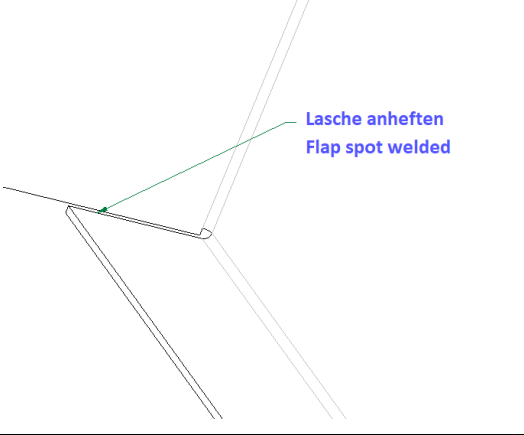
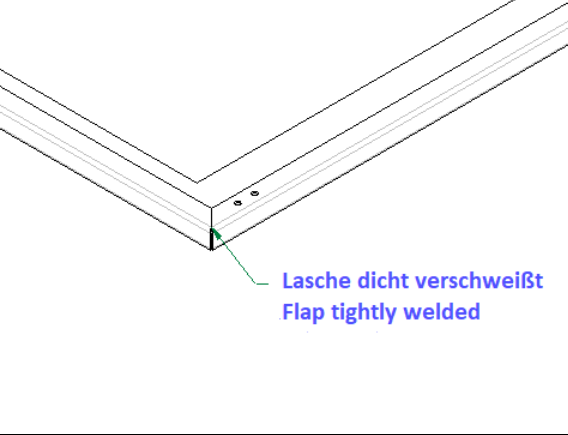
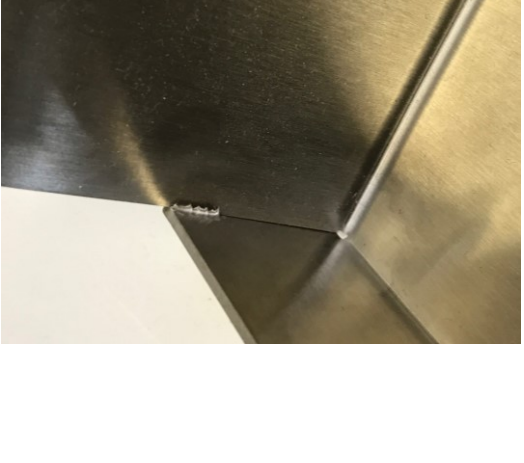
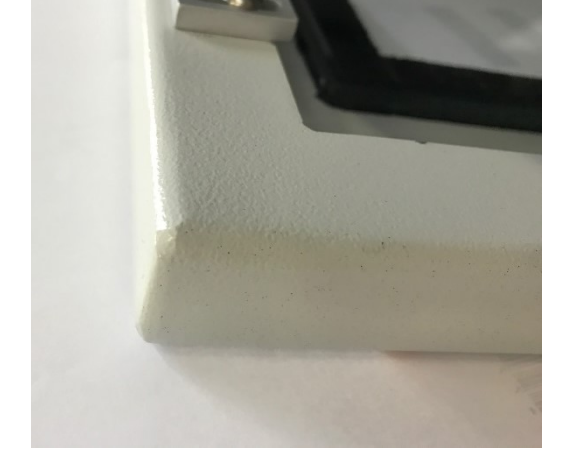
Leakproof welded	Tightly welded
	
	
<p>The flaps should only be welded together at certain points (mainly for reasons of rigidity).</p>	<p>tight welding + rounding (optics after powder coating see bending edge)</p>

- **Grinding of welded edges**

If no "visible edge" is indicated on the drawings or if there is an indication that the welded edges are to be ground, they may remain unmachined.



- **Powder coating of folded components**

Edged components that are powder-coated must be stapled from edge to edge to avoid coating cracks later on. If it is not clearly stated where stapling is permitted or where stapling is not permitted, telephone consultation should be held. (Phone: 09621/67 54 214)

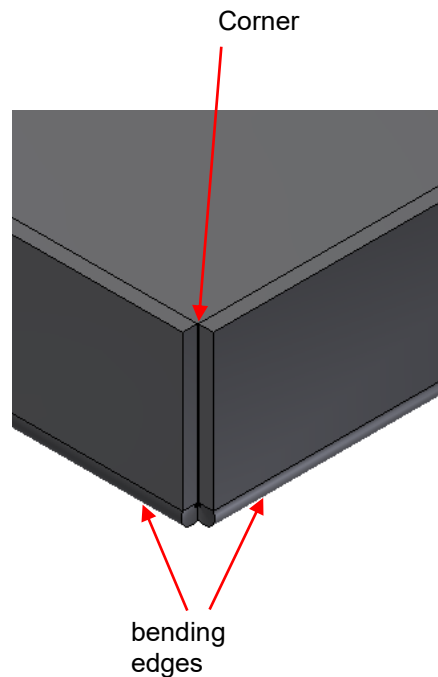

Set the tacking points as shown on the drawing!
(inside or outside)

- **Welding of hinge part Dirak 243-9001 (article number 100-071-232)**

Baumann mainly uses this hinge for the storage of cladding doors. It may be used by the supplier as a welded version and as a version fixed with welding studs. The following must be observed for the welded version:

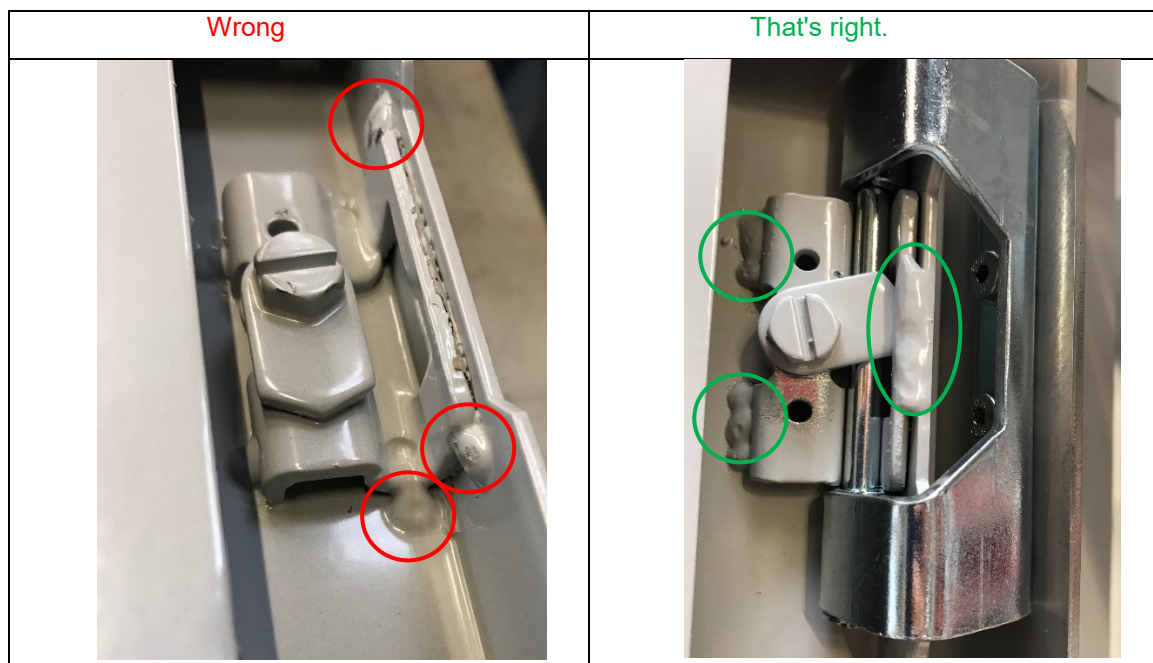

<p>Version: 1.0.12 Status: 26.06.2020 Page 11 of 25</p>	<p>specification production parts</p>	<p><small>AUTOMATION</small> baumann</p> <p>Released by: StrobelJo</p>
---	--	---

Version: 1.0.12 Status: 26.06.2020 Page 12 of 25	specification production parts	<small>AUTOMATION</small> baumann Released by: StrobelJo
---	---	--

- **Inserting rivet nuts**

Rivet nuts are generally only riveted by Baumann itself. If there is a note on the drawing regarding a rivet nut, only the corresponding bore should be made for it. If the required diameter is not apparent from the drawing, please contact us by telephone. (Phone: 09621/67 54 214)

- **Galvanized sheets**

If galvanized is indicated in the marking field for the material (e.g. S235JR, galvanized), an already galvanized sheet may be used as semi-finished product. It doesn't need to be galvanized again afterwards.

If galvanized is indicated as the surface specification above the marking field, the finished component must be galvanized.

8 Requirements for test objects/measurement logs

If it is necessary to draw up a measurement protocol, the following requirements shall apply:

- Measurement report generation is only necessary for marked dimensions and marked form and position tolerances.
- The number must be applied permanently and not raised (e.g. laser engraved).
- Entry only allowed in marked area
- A protocol in pdf format must be created for each article number.
 - Name: Order No. _Art.No.pdf
- Engraving, which is written on the part, is also to be mentioned in the protocol.
- The entry shall be made in the following format:

2012-12-31 / Y.xx

Coding:

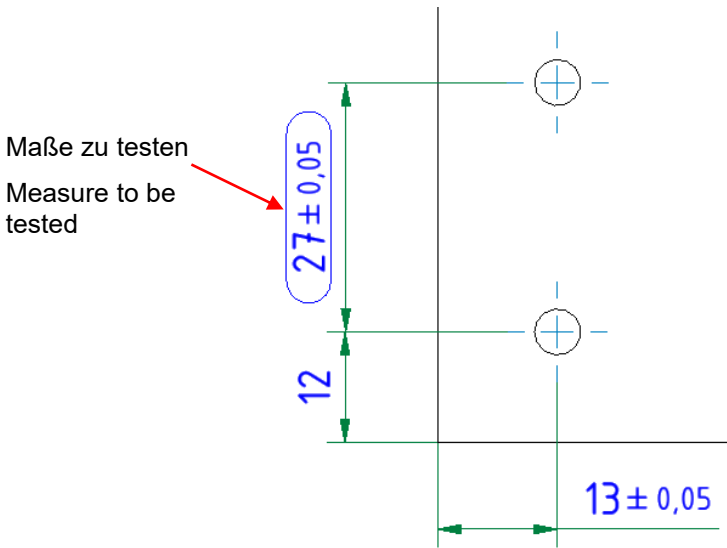
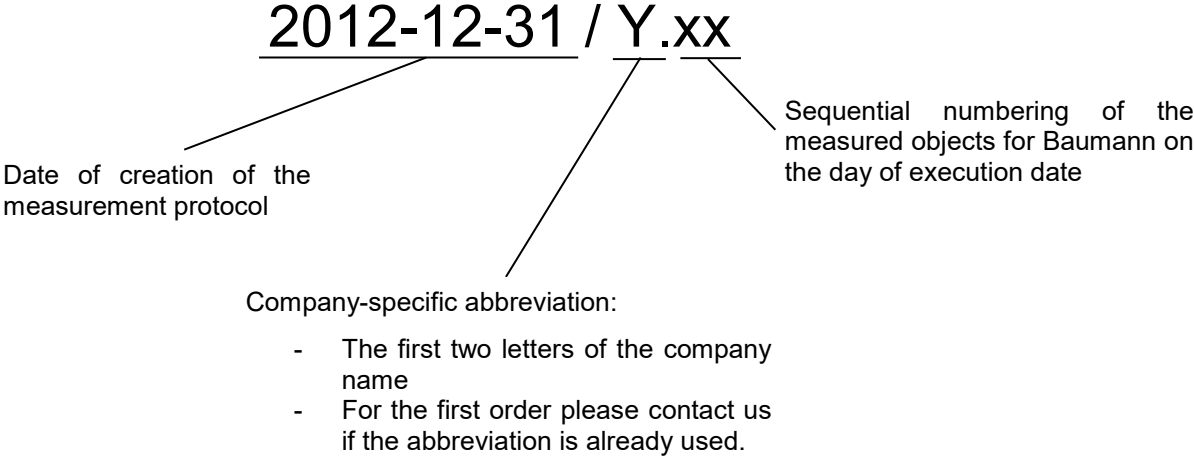

Version: 1.0.12 Status: 26.06.2020 Page 14 of 25	specification production parts	<div style="text-align: right; background-color: #cccccc; padding: 2px;"> <small>AUTOMATION</small> baumann </div> Released by: StrobelJo
---	---	--

9 Requirements for welded parts

In the case of welded parts, no or not all permissible weld seams are usually drawn in under normal requirements. A professional welding adapted to the dimension of the parts is assumed.

Please note that areas where welding is not permitted are clearly marked on the drawing with a note:

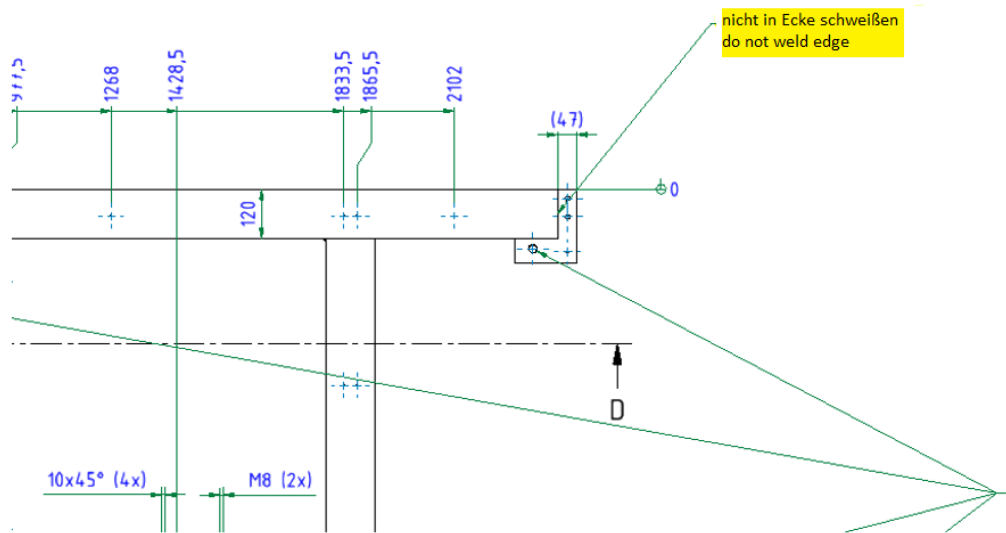

All non-tolerated dimensions and unmachined surfaces of welded parts shall be manufactured in accordance with the general tolerance DIN EN ISO 13920 B.

Furthermore, no slag residues and welding beads must remain on the component. Any protruding weld seams on the outer sides must be sanded. Professional or "clean" welding seams do not have to be plastered.

- **Preparation and post-processing of welded parts for powder coating/painting**

All components must be cleared of residues (chips, cutting oils, etc.) by the paver prior to coating. Particular attention must be paid to elements such as blind bores and threads.

It must also be ensured that threads are not soiled by powder residues after coating. This can be achieved either by clean covering beforehand or by re-cutting the threads.

10 Requirements for glass panes

In the case of glass components, the comments (e.g. anti-reflective on one side, anti-reflective on both sides, etc.) on the drawings must be taken into account and manufactured as specified. If various stamps have to be provided (e.g. safety glass), these should be attached to the edge if possible. For glass components, the general tolerances according to DIN ISO 2768-mk are invalid. In this case, the following tolerances are permitted:

Permissible tolerances for glass panes - other	
evenness	approx. 1.5 mm per meter length
parallelism	1,5mm per meter length
Dimensional tolerances in mm	+ 0 - 2
Tolerance of chamfers in mm	1 x 45 ± 0,5
Bore distance tolerance between bores in mm	± 0,5
Bore distance tolerance from first bore to outer edge in mm	± 1
bore diameter	+ 0 - 0,5

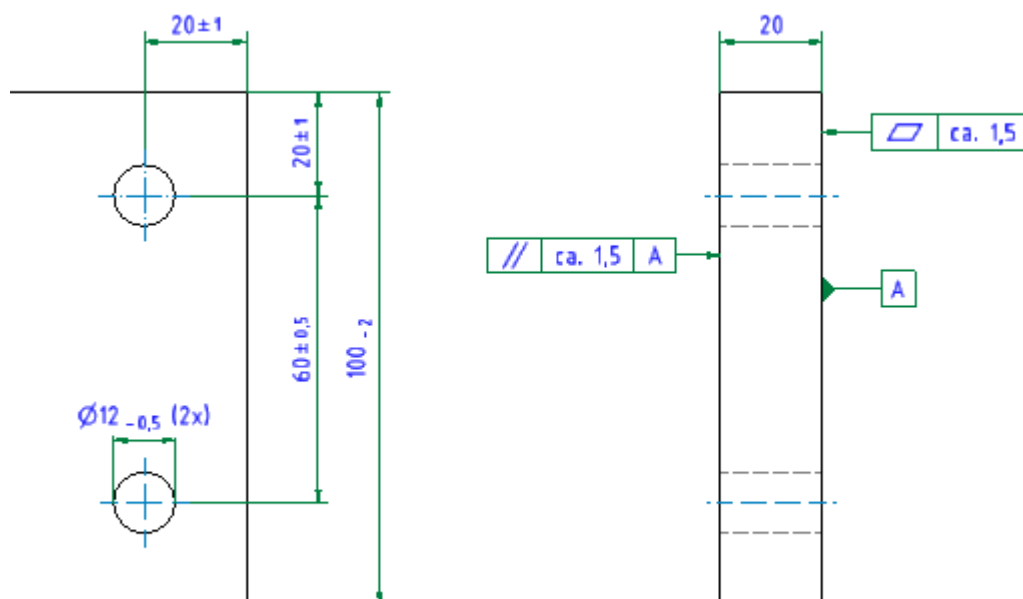

Version: 1.0.12 Status: 26.06.2020 Page 16 of 25	specification production parts	<div style="text-align: right;"> <small>AUTOMATION</small> baumann </div> Released by: StrobelJo
---	---	---

11 tidiness

All production parts must be delivered in a clean, visually appealing condition. A visual inspection for uniform surface quality, stains, scratches and scale residues (etc.) must be carried out by the supplier.

12 ESD

- **Definition of ESD (Source: www.wikipedia.de)**

Electrostatic discharge (ESD) is a spark or breakdown caused by a large potential difference that causes a short, high electrical voltage pulse on an electrical device. Under unfavourable circumstances, this voltage pulse in the device can damage electrical components. This particularly affects field effect transistors. Another undesirable consequence may be the uncontrolled ignition of combustible gas. The cause of the potential difference is usually charging due to frictional electricity.

- **ESD capability**

If an ESD capability is required, the assembly/component must have a leakage resistance of $\leq 1\text{G}\Omega$ at every point. The surface resistance of the entire assembly/component must not exceed the limit resistance of $R_{O_grenz} \leq 1\text{G}\Omega$.

13 Painting/surface coating

For components to be painted, care must be taken to ensure an optically clean surface and professional workmanship. The substrate of the paint must be treated according to the paint manufacturer's specifications. If nothing to the contrary is indicated on the drawing, over-milled surfaces should only be painted, not primed, for reasons of accuracy.

The surface coating must be clean, uniform and free of stains. Blue chromated parts must not have a yellowish tinge. Prior to coating, blind holes must be blown out to prevent corrosive salts from leaking later.

The drawings always indicate the fit required at the end of the manufacturing and surface treatment process.

If a surface treatment produces an application layer that changes the fit, this must be taken into account during production. An indication or adjustment in this respect in the drawing is not made!

The indicated dimensions and tolerances ALWAYS refer to the finished coated component.

Example:

For blue chromated parts, the layer thickness of 8-12 μm (\varnothing 10 μm) must be taken into account during production. For example, when manufacturing a slot with tolerance **4H7** (EI = **0**; ES = **+12**), the tolerance field must be shifted by **2 x 0.01mm** during manufacturing. Thus the permissible tolerance for manufacturing is: **4.020 to 4.032**.

After the surface coating, the measurement is in the range of 3.996 to 4.016.

Exceeding the tolerance in the upper range is compensated by the stronger edge structure and is accepted. Bores such as \varnothing 6H7 are to be produced with a standard plus reamer \varnothing 6,02.

Version: 1.0.12 Status: 26.06.2020 Page 17 of 25	specification production parts	<small>AUTOMATION</small> baumann Released by: StrobelJo
---	---	--

For blind bores, it is accepted that these are only coated at the top edge and are therefore too large at the bottom. For external dimensions, the above applies analogously to minus.

Plasma nitrided parts are always additionally oxidized with plasma. Oxidation gives the parts corrosion protection.

For chemically nickel-plated components, the layer thickness of 8-11 µm must also be taken into account. Due to the more precise coating, tolerances of 0.02 can be maintained.

If a stainless steel is vacuum-hardened, it must remain corrosion-resistant even after tempering.

Components with the drawing specification "blue chromated" can also be chemically nickel plated. However, this does **not** apply in the opposite sense!

Unless otherwise stated on the drawing, the following layer thicknesses must be adhered to as standard:

Standard coating thicknesses for surface coatings	
surface treatment	coating thickness
anodize	~ 10µm
Hard coat	~ 25µm
Blue chromate	~ 5 - 10µm
Black chromate	~ 5 - 10µm
Chemical nickel plating	8 ⁺³ µm

Aluminum parts

The surface treatment indicated on the drawing must be carried out.

Hard coating

The electrical contact point of the parts during hard coating must under no circumstances lie on mating surfaces. Threads are preferred. If no threads are available, a thread must be inserted after consultation with the drawing info!

Version: 1.0.12 Status: 26.06.2020 Page 18 of 25	specification production parts	<div style="text-align: right; background-color: #cccccc; padding: 2px;"> <small>AUTOMATION</small> baumann </div> Released by: StrobelJo
---	---	--

14 Quality, packaging and delivery conditions

The quality of external supplies directly contributes to the quality of our products. We therefore expect high quality from our suppliers for all delivered materials and production parts. We strive for a close and trusting cooperation with our suppliers with the aim of continuously improving quality and achieving zero-defect quality as well as 100% adherence to delivery dates.

The general quality, packaging and delivery conditions for production parts apply to all deliveries of materials and production parts.

The components must preferably be wrapped in foil in order to avoid possible damage to the other components by escaping salts after surface treatment. Alternatively, the components can also be wrapped in paper or packed in boxes or bags. When packing, it must be ensured that it is labelled with the corresponding Baumann article number. Ideally, a sticker is used which is **not** attached directly to the components. However, it is also possible to fix the label with a foil or to label the foil/paper with a suitable pen. The only important thing is that the article number is attached in such a way that it is immediately visible.

Upon delivery, it is important to ensure that the article number, article description, quantity and order number are noted on the delivery note. Further details for delivery can be found in the valid "Terms and Conditions of Purchase" or by telephone.

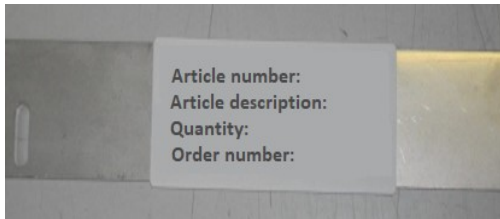

Changes

In any case it requires our written approval that changes may be carried out. Drawings must be used in the respective valid version.

15 complaint

Should we receive a complaint from the supplier in spite of an outgoing goods inspection, the supplier will be contacted immediately, if necessary with pictures and measurement reports. The rework or new production must be carried out in the quickest way under the responsibility of the supplier.

The shipping costs from our company to the supplier and back will be borne by the supplier.

In exceptional cases and after consultation, as well as previous cost clarification, the rework can also be carried out in our house.

The procedure in the event of a complaint must be coordinated individually in each case.

16 key to the symbols

- **tight welding of pipes - weld pipes closed**

Under "Pipe tight welding" a tightness for liquids is required. A standard test certificate for the tightness of the pipes is not required. The tightness of the entire system is only checked in suspicious cases. The exact conduct of the audit must be determined and agreed in each individual case.

- **flap tightly welded - flap leakproof welded**

A tightness for liquids is required under "Flap tightly welded". A standard test certificate for the tightness of the lugs is not required unless explicitly required. The tightness of the entire system is only checked in suspicious cases. The exact conduct of the audit must be determined and agreed in each individual case.

- **Parts must be welded together light-proof - Parts together light-proof welded**

A standard test certificate for the light-tightness of the assemblies is not required unless explicitly required. Only in the event of problems is an inspection to be carried out after prior consultation and, if necessary, reworking carried out.

- **Edge states**

Unless otherwise stated, the parts may also not be supplied burr-free and with sharp edges. If the drawing does not contain any other information on the machining of workpiece edges, all edges must be deburred as follows:

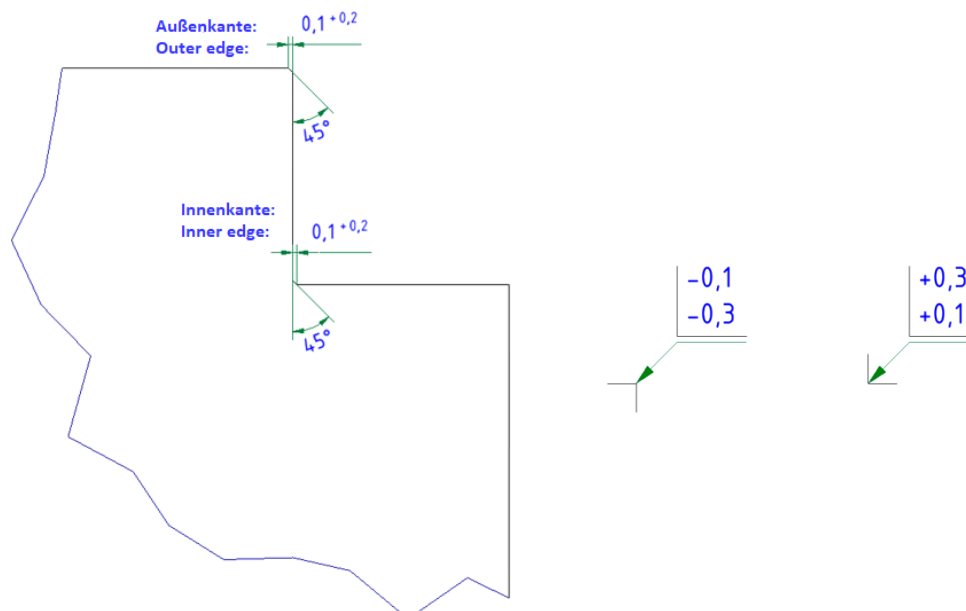

- surface finish**

If there is no information on the surface tolerances on the drawing, all surfaces to be machined must be produced with the surface quality Ra 12.5 or better. If no surface specification for unmachined surfaces is given on the drawing, these surfaces may remain in the raw state. If the surface Ra 6.3 is specified for aluminium parts, the saw edges do not need to be milled over.

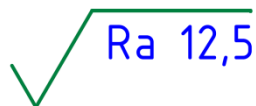

Surface symbol

Machined surface

- stainless steel ground**

If there is a reference to ground surfaces on the drawing, the specified brushing direction and grain size must be observed.

Description of the brushing directions:

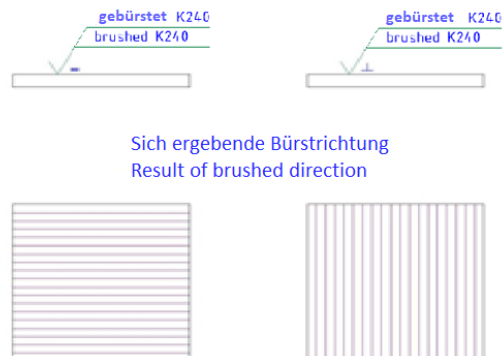

Version: 1.0.12 Status: 26.06.2020 Page 21 of 25	specification production parts	<div style="text-align: right; border: 1px solid black; padding: 2px;"> <small>AUTOMATION</small> baumann </div> Released by: StrobelJo
---	---	--

- **fitting bores**

für alle Passbohrungen einer
Bearbeitungsebene ohne
Toleranzangabe gilt:

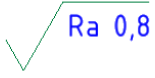
Positionsgenauigkeit
zueinander $\pm 0,02$ 

for each fitting bore
in one machining plane without
tolerance indication applied:

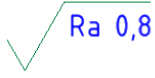
positional tolerance
to each other $\pm 0,02$ 

The following tolerances or surface roughnesses apply to all fitting bores in a working plane that **do not have a** separate tolerance or surface specification in the drawing:

Position accuracy of the fitting bores in relation to each other	$\pm 0,02$
surface roughnesses	Ra 0.8
Angularity to flat surface	$\pm 0,05^\circ$

In most cases, the tolerance of the bores to each other is defined, not the dimension towards an outer edge (see drawing example below). Here the general tolerance indicated on the drawing continues to apply.

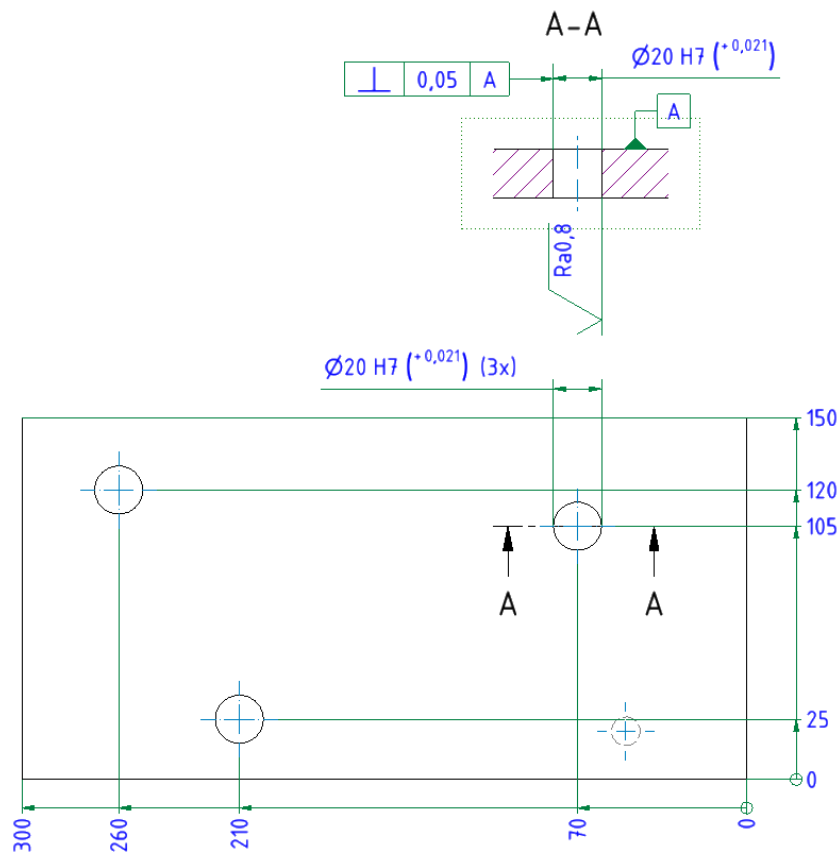

Description of the above drawing example:

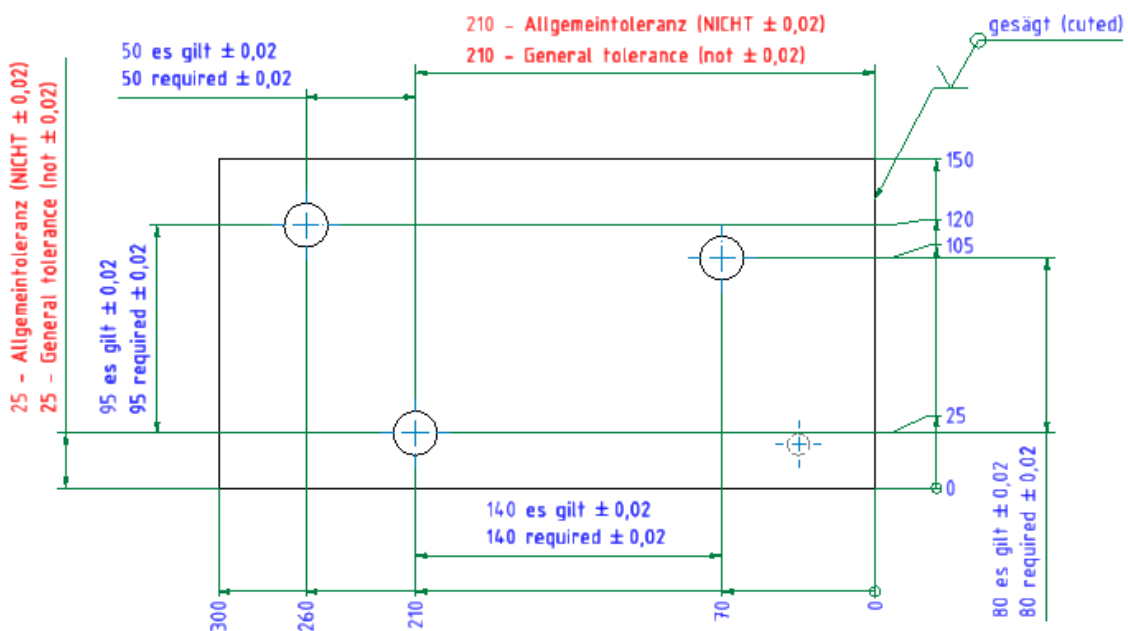

The following special cases are possible:

Version: 1.0.12 Status: 26.06.2020 Page 23 of 25	specification production parts	<small>AUTOMATION</small> baumann Released by: StrobelJo
---	---	--

- If a tolerance from the bore to the outer edge is required, this dimension is tolerated separately.
- If the distances between bores of different machining planes must be provided with a tolerance, this distance is dimensioned and tolerated.
- If the position accuracies of the drill bores have to be measured, the dimension is specified as a function-related test dimension (see point 8).

Version: 1.0.12 Status: 26.06.2020 Page 24 of 25	specification production parts	 Released by: StrobelJo
---	---	---

17 document history

Document History					
Ver- sion	booth	Created by	Tested by	releasing pass	reason for change
1.0	27.11.2014	StrobelJo	WeigertAl	StrobelJo	new plant
1.0.1	03.12.2014	StrobelJo	WeigertAl	StrobelJo	Buxfix, position accuracy was incorrectly specified instead of +-0,04 now +-0,02
1.0.2	11.08.2015	StrobelJo	WeigertAl	StrobelJo	Page 11: "If a stainless steel is vacuum-hardened, it must always remain corrosion-resistant even after tempering". Add
1.0.3	26.01.2016	StrobelJo	WeigertAl	StrobelJo	Point 8: Measurement report generation is only necessary for marked dimensions and <u>marked</u> form and position tolerances. was Measurement report generation is only necessary for marked dimensions and <u>all</u> form and position tolerances. Point two: - New title block added and article number updated
1.0.4	28.07.2016	DuxMa	WeigertAl	StrobelJo	Drawings revised, adapted to Baumann standard specifications. Point 5: Surface roughness of aluminium plate was indicated as Ra 0.8, now Ra 3.2 Point 4: supplemented by drawing
1.0.5	27.10.2016	DuxMa	WeigertAl	StrobelJo	Item 7: -For the "Attach straps" or "Tightly welded straps" specifications, add the following
1.0.6	11.04.2017	DuxMa	WeigertAl	StrobelJo	Point 9: Welding of hinge part Dirak 243-9001 added
1.0.7	18.09.2017	StrobelJo	WeigertAl	StrobelJo	- Item 9: Preparation and post-processing of welded parts for powder coating/painting added, example for "do not weld here" added - Change from 11.04.2017 postponed to item 8

Version: 1.0.12 Status: 26.06.2020 Page 25 of 25	specification production parts	<div style="background-color: #cccccc; padding: 2px; display: inline-block;"> <small>AUTOMATION</small> baumann </div> Released by: StrobelJo
---	--	---

1.0.8	02.02.2018	DuxMa	WeigertAl	StrobelJo	Point 16: Section "Fitting holes" revised
1.0.9	27.07.2018	DuxMa	WeigertAl	StrobelJo	Point 6: Engravings readable + example added
1.0.10	05.04.2019	DuxMa	WeigertAl	StrobelJo	Chapter 13: - Contact point added for hard coating - If nothing to the contrary is indicated on the drawing, over-milled surfaces should only be painted, not primed, for reasons of accuracy.
1.0.11	06.12.2019	DuxMa	WeigertAl	StrobelJo	Chapter 13: not applicable to aluminium parts: No treatment may be carried out for any specification. Glass bead blasting is not required for components larger than 300x200 or longer than 300mm. Chapter 16: Stainless steel sheet now "ground K240" instead of "brushed K320". Chapter 14: changed completely Chapter 7: Dimensioning of sheet metal parts added
1.0.12	26.06.2020	StrobelJo	DuxMa	StrobelJo	Chapter 7: Area elements added for dimensioning rule Chapter 3: Pretreated semi-finished products added Chapter 2: Change index+revision explained Chapter 13: chemical nickel-plated: layer thickness: 8+3µm Chapter 3: Information on plastic protective screens added